



Metalkas®



Scaffale in metallo Metal shelving Lagerregal aus Metall



 **1800 x 1800 x 600 mm**

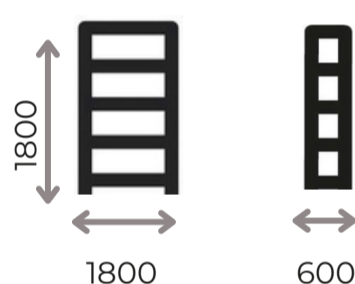

IT Il colore della scaffalatura sulla stampa può essere leggermente differiscono dal colore effettivo del prodotto
EN The colour of the shelving on the printout may slightly differ from the actual product colour
DE Die Farbe des Regals auf einem Ausdruck kann geringfügig von der tatsächlichen Produktfarbe abweichen



IT Nero
EN Black
DE Schwarz

IT 4 mensole in HDF
EN 4 HDF shelves
DE 4 HDF-Böden

IT Max. 250 kg per mensola
EN Max. 250 kg per shelf
DE Max. 250 kg pro Böden

IT Assemblaggio senza bulloni
EN Boltless assembly
DE Push-in-Montage

IT Ideale per molti utilizzi
EN Ideal for many uses
DE Ideal für viele Anwendungen

IT Stabile, per lo stoccaggio di oggetti pesanti
EN Stable for storing heavy items
DE Stabil, zur Lagerung schwerer Gegenstände

Disporre il carico sui ripiani in modo uniforme e distribuito, non superare la portata massima dichiarata. Controllare la struttura periodicamente nel tempo

Arrange the load on shelves so it's uniformly distributed, without exceeding the maximum load. Check periodically the structure.

Verteilen Sie die Last gleichmäßig auf den Regalen, ohne die maximale Belastung zu überschreiten. Überprüfen Sie die Struktur regelmäßig.



Art. Nr. 571164

Metalkas S.A. // 85-227 Bydgoszcz // ul. Artura Grottgera 4 // Poland
tel. +48 52 372 27 47 fax +48 52 349 01 98 // biuro@metalkas.com.pl // www.metalkas.pl

Il nome e il marchio di METALKAS sono riservati a Metalkas S.A. Garanzia e servizio post-garanzia in tutto il paese
The name and trademark of METALKAS is reserved by Metalkas S.A. Warranty and post-warranty service throughout the country
Der Name und die Marke METALKAS sind eingetragen von Metalkas S.A. Garantie und Service nach Ablauf der Garantie im ganzen Land

Made in Poland

Etichetta/Label
Carta/Paper



Pellicola/Film
Plastica/Plastic



Verifica le disposizioni del tuo Comune / Check your local guidelines

Importante - Conservare per un uso successivo - Leggere attentamente | Scaffalatura metallica P1 1800x1800x600-P4 / 250 kg
 Important: Keep for later use. Read carefully | Metal shelving P1 1800x1800x600-P4 / 250 kg
 Wichtig: Bis zum nächsten Gebrauch aufbewahren - aufmerksam lesen | Metallregal P1 1800x1800x600-P4 / 250 kg

Elenco degli elementi | List of elements | Liste der Elemente

A x 4	B x 4	C2 x 8
	C1 x 8	D x 8
		F x 8

Spiegazione dei segni | Explanation of the signs | Erklärung der Zeichen

	Corretto Properly Richtig		Direzione di montaggio Direction of assembly Richtung der Montage
	Errato Wrong Falsch		Premere Push Drücken
A	Indicazione dell'elemento Designation of the element Bezeichnung des Elements		Piega il dettaglio di 180° Bend the detail by 180° Das Element um 180° biegen
	Attenzione Note Achtung		

Necessario per il montaggio | Required for assembly | Zur Montage erforderlich

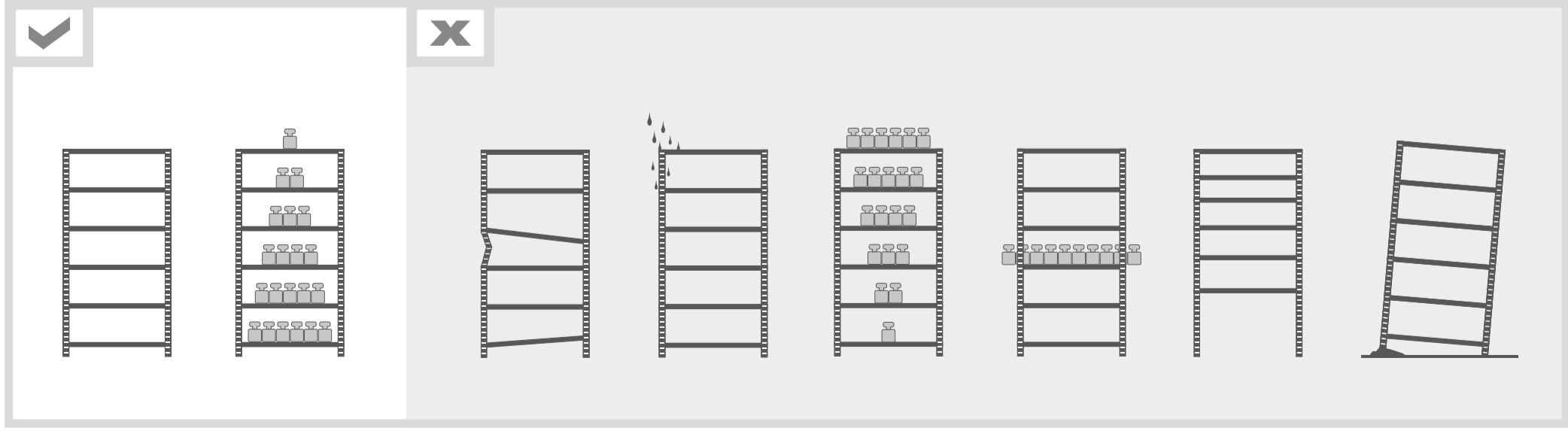
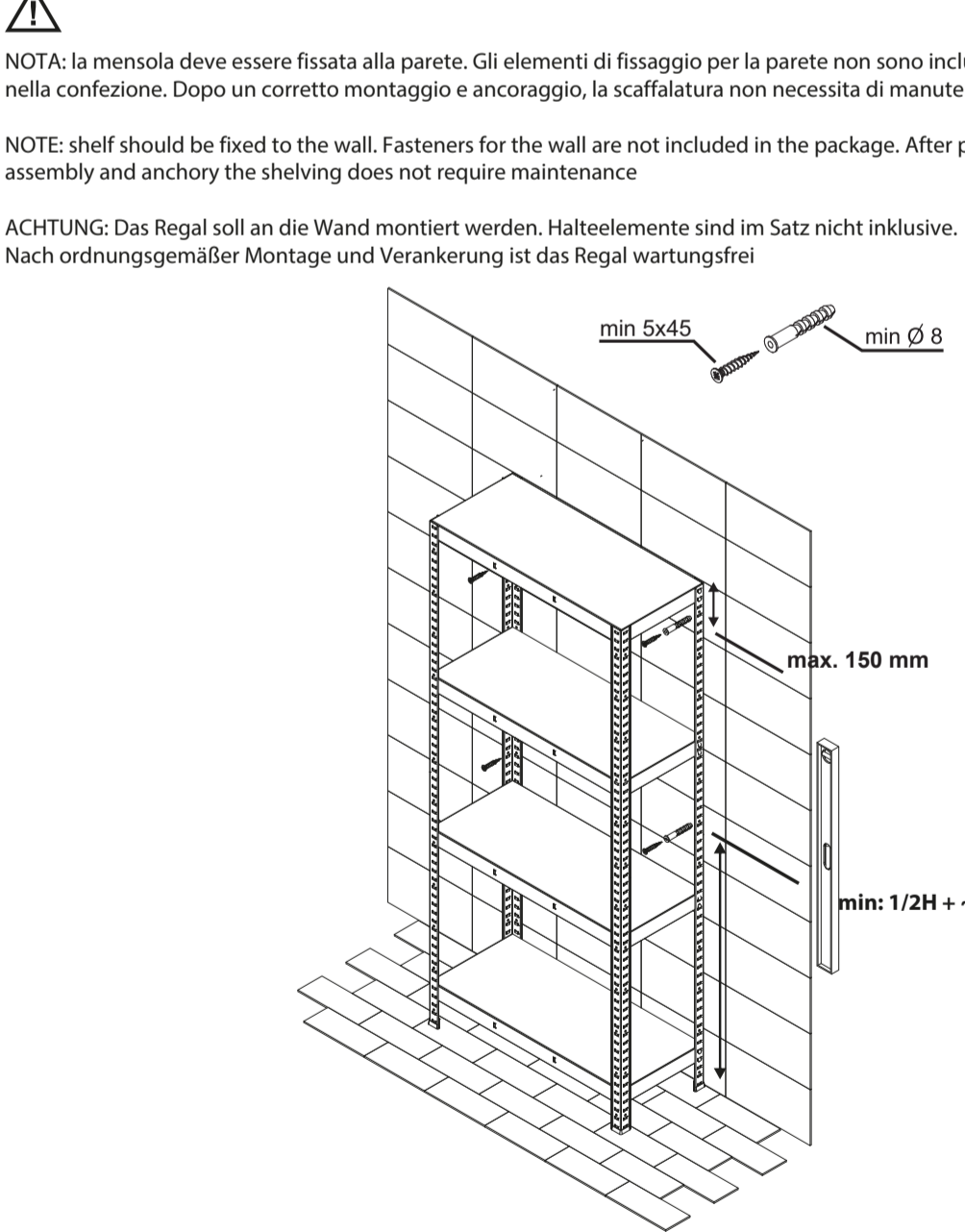
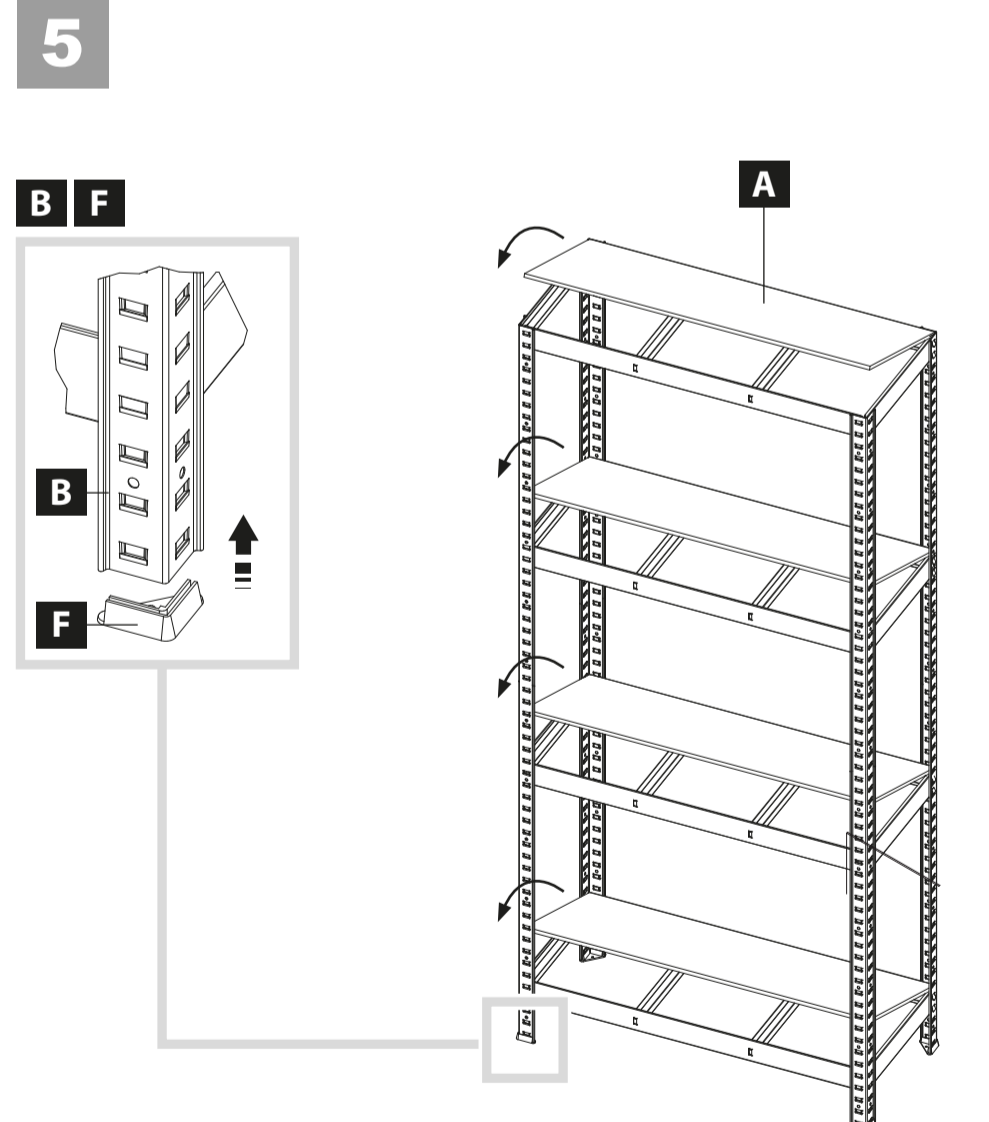
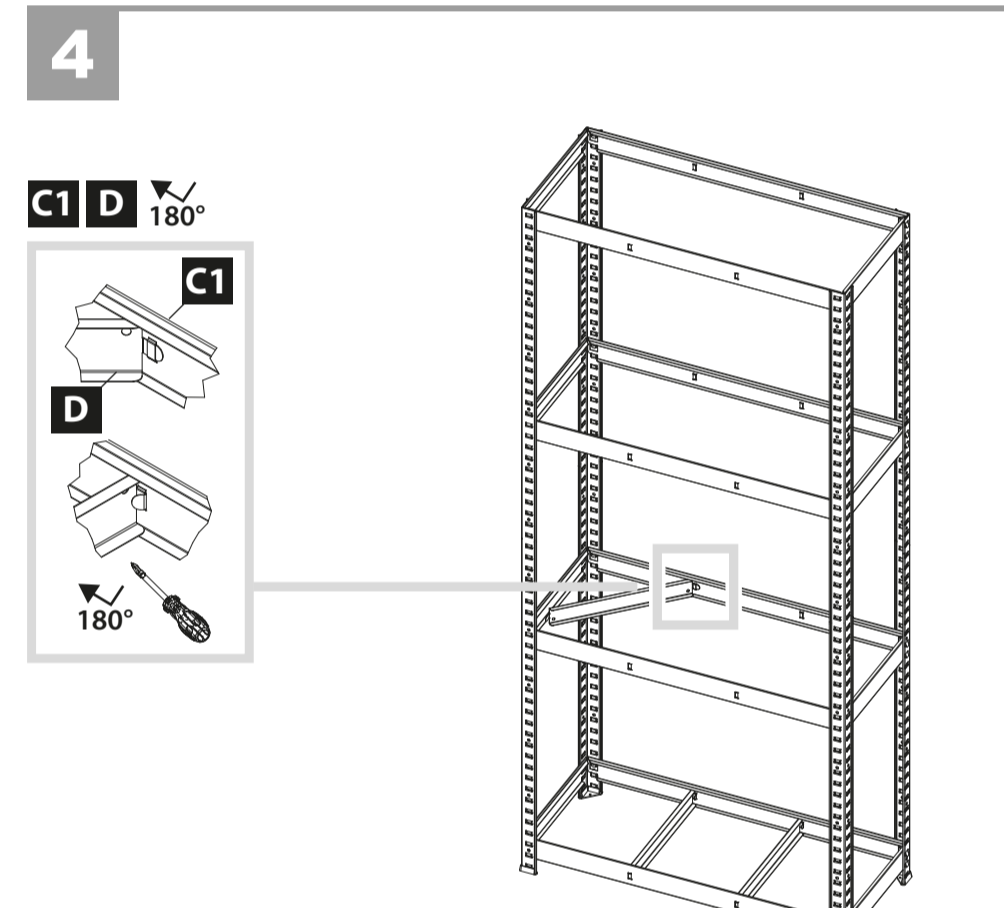
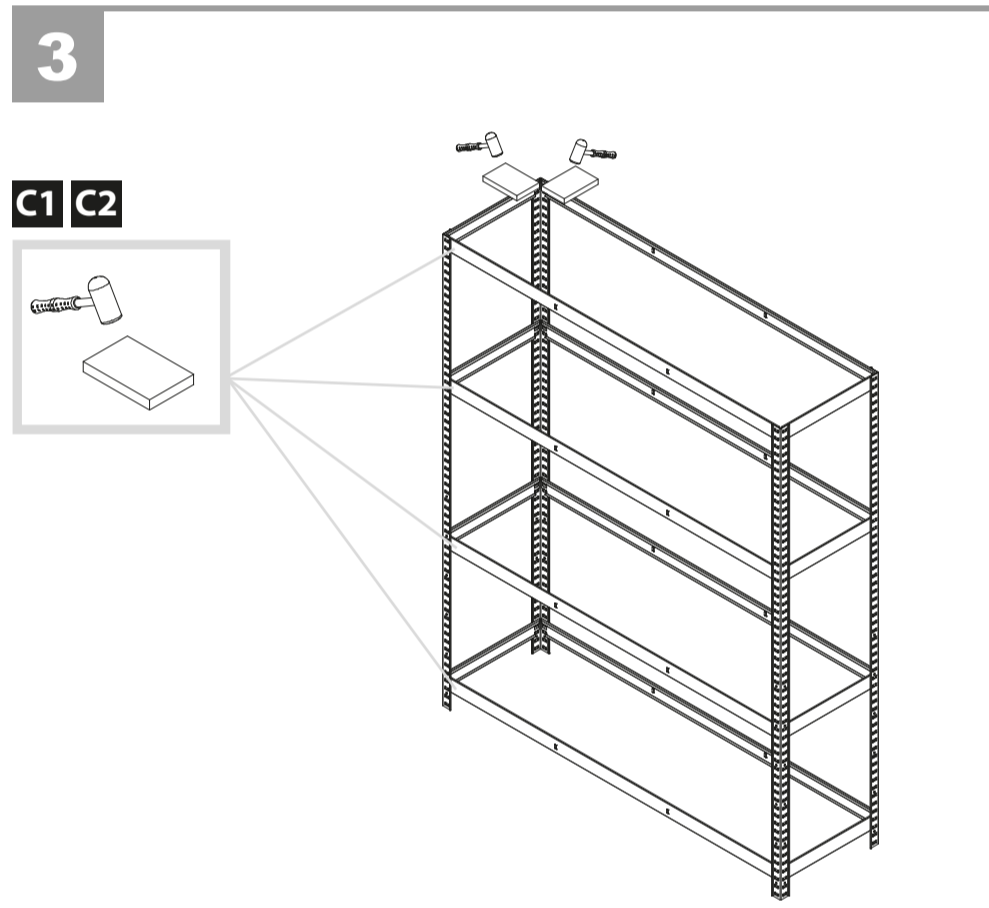
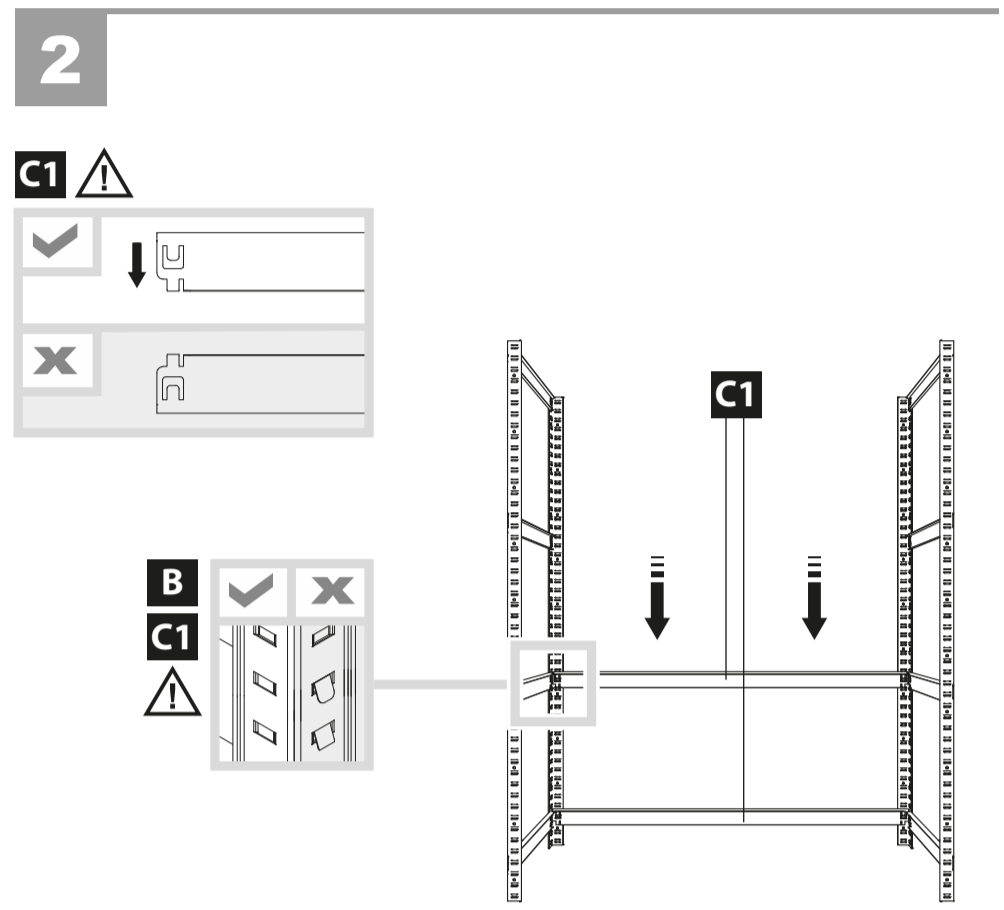
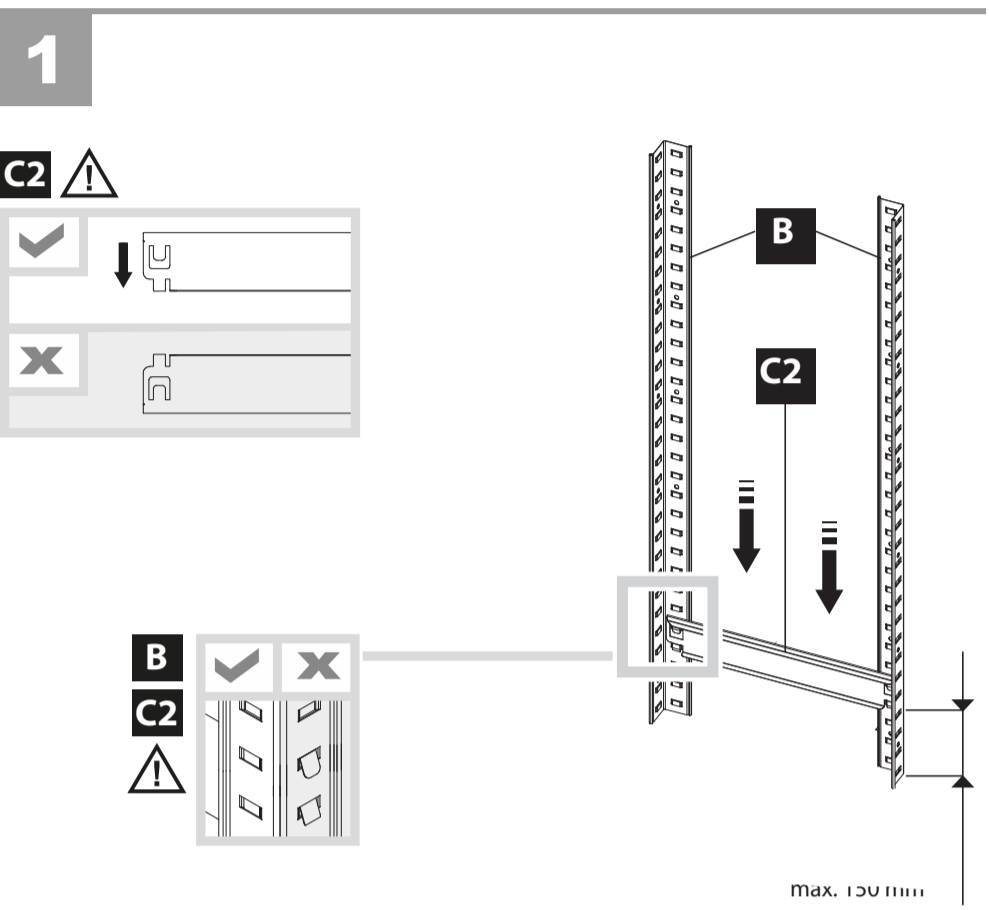

Esonero di responsabilità: il produttore declina ogni responsabilità per danni derivanti da un montaggio improprio o da un utilizzo dello scaffale contrario allo scopo previsto. Il montaggio e l'installazione degli scaffali devono essere eseguiti esattamente secondo le istruzioni del produttore, altrimenti sussiste il rischio di pericolo per la sicurezza. Utilizzare solo tasselli e viti di fissaggio adeguati al tipo di muro e al cavo della scaffalatura (tasselli o viti e attrezzi per il fissaggio al muro non sono compresi con la scaffalatura). Attenzione: durante il montaggio prestare attenzione alle linee elettriche e alle tubazioni dell'acqua!

Disclaimer: the manufacturer disclaims liability for damages resulting from improper assembly or use of the shelving against its intended purpose. Assembly and installation of the shelving should be carried out exactly in accordance with the manufacturer's instructions - otherwise there is a risk of a safety hazard. Only use dowels and fixing screws appropriate for the type of wall and shelving lead (dowels or screws and tools for fixing to the wall are not included with the shelving). Attention: during assembly, please pay attention to electric lines and water pipes!

Haftungsausschluss: Der Hersteller übernimmt keine Haftung für Schäden, die durch unsachgemäße Montage oder nicht bestimmungsgemäße Verwendung des Regals entstehen. Die Montage und Installation des Regals sollte genau nach den Anweisungen des Herstellers erfolgen - andernfalls besteht die Gefahr einer Gefährdung der Sicherheit. Verwenden Sie nur Dübel und Befestigungsschrauben, die für die Art der Wand und des Regals geeignet sind (Dübel bzw. Schrauben und Werkzeug zur Befestigung an der Wand sind nicht im Lieferumfang des Regals enthalten). Achtung: Achten Sie bei der Montage bitte auf Elektro- und Wasserleitungen!